

COMPACT CNC LATHE

UNIVERSAL TURNING CENTRE! UNITURN 200



Legacy continues..



SALIENT FEATURES

- Legendary spindle precision of < 0.003 mm.
- A wide range of spindle sizes (A2-5 LB and A2-6) and spindle Power (5.5Kw/ 7.5Kw).
- Tailstock available optionally.

Latest State-of-the-art CNC Controller from Fanuc with Custom Screens

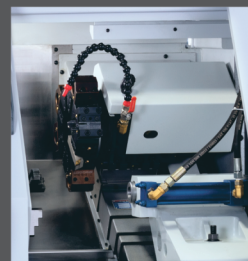

MADE IN INDIA
MADE FOR THE WORLD

INDIA'S No.1 EXPORTER of lathes to GERMANY

GEDEE WEILER

A CUT ABOVE THE REST

UNITURN 200 - TECHNICAL SPECIFICATIONS

DESCRIPTION		UNIT	UT-25 ^(**)	UT-42	UT-51
CAPACITY	Swing Over Protection-Dia	mm		450	
	Swing Over Cross Slide Cover-Dia	mm		170	
	Admit Between Centers	mm		200	
	Max Turning Dia / Length	mm		160x200**	
	Max Bar Capacity Dia	mm	25*	42*	51*
SPINDLE	Chuck Size - Dia	mm	135	165	200
	Spindle Through Bore-Dia	mm	38	58	63
	Spindle Nose Din 55026	type	A2-4	A2-5 LB	A2-6
	Spindle Speed	rpm	50-4000		
TRAVEL	X Axis Travel	mm	155		
	Z Axis Travel	mm	280		
FEED RATE	Rapid Traverse X Axis	mts/min	20		
	Rapid Traverse Z Axis	mts/min	25		
	Feed Rate	mm/min	6000		
TURRET	Type		BTP 63		
	No Of Tool Positions	No	8		
	Tool Shank Size	mm	20X20		
	Boring Bar Size Dia	mm	32		
TAIL STOCK (OPTION)	Quill Dia	mm	55		
	Quill Stroke	mm	110		
	Quill Taper	type	MT4		
MACHINE SIZE	Floor Space (L x W x H)	mm	1750x1600x1600		
	Machine Weight (Approx)	kg	2000	2050	2100
CNC CONTROLLER	Siemens/Fanuc/Mitsubishi	type	808D PPU161 / 828D / Oi TF / E-80		
MOTOR POWER	Spindle Motor Rated Power (Continuous Rating)	kw	V1-3.7KW Mit/ Fanuc/Siemens	V2-5.5KW Mit/ Fanuc/Siemens	

STANDARD ACCESSORIES

- Hydraulic Chuck And Closed Cylinder
- One Set Of Soft Jaws
- Hydraulic Power Pack
- Coolant Supply Equipment
- Centralized Lubrication Equipment
- Chip Trolley
- Work Light
- Foot Switch
- 8 Station Bi- Directional Turret "Pragati Btp-63" With 3 Boring & 1- Face Grooving Tool Holder
- Set Of Manuals
- Machine Mounting Pads

OPTIONAL ACCESSORIES

- Memory Card
- Adaptor For Memory Card
- Chip Conveyor
- Coolant Gun
- Panel A/c
- Air Blast For Chuck Jaw Cleaning
- Aden Lamp (yellow / Red / Green)
- Additional Boring Sleeves
- Collet Chuck (dead Length / 5c Attachment)
- Hollow Cylinder
- Hydraulic Tailstock

* Max bar size vary with respect to draw bar bush thickness. ** Depend upon clamping arrangement, Tooling & Job.

(**)In case of A2-4 Spindle consult us for your requirements

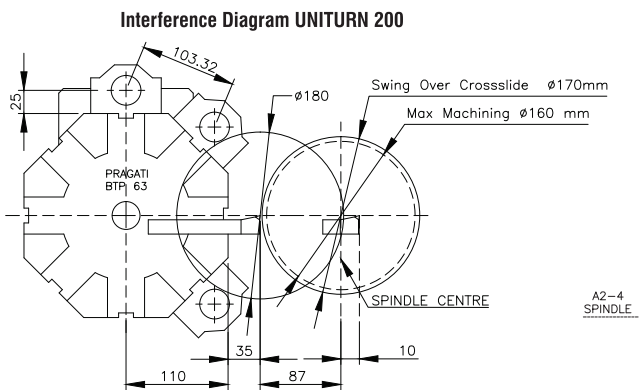

Machining Range Uniturn-200 CHUCKER DIA.135 CHUCK(WITHOUT TAILSTOCK)

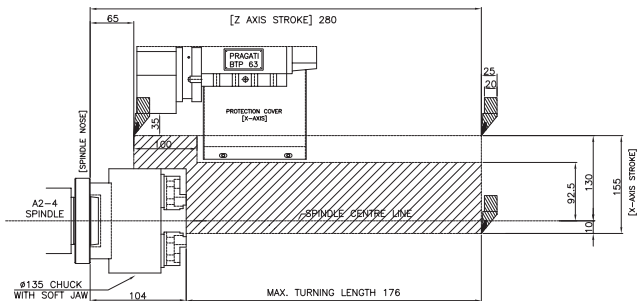

Note : Due to continuous upgradation of our products, the specifications are subject to change without notice.

Machining Range Uniturn-200 CHUCKER (WITHOUT TAILSTOCK)

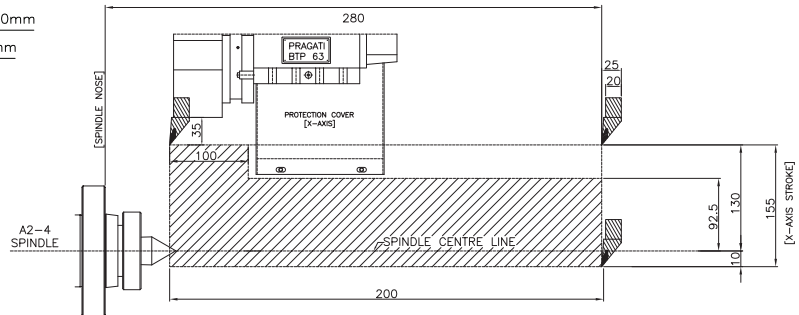

Machining Range Uniturn-200 CHUCKER DIA.165 CHUCK (WITHOUT TAILSTOCK)

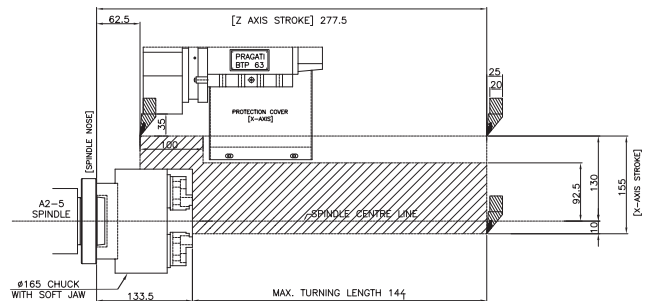

India's No.1 EXPORTER of lathes to GERMANY

GEDEE WEILER

A CUT ABOVE THE REST

GEDEE WEILER PRIVATE LIMITED,

Vellalore Road, Podanur P.O. Coimbatore - 641 023, Tamil Nadu, INDIA.

EPABX: +91-422 2413908, 804 and 048 E-mail: sales@gdweiler.com

Website: www.gdweiler.com

